

Modelo	Ref.	Potencia (HP)	Voltaje	H max. (mca) *	Q max. (GPM) **	Succión	Descarga	Peso (kg)
HE 1.5 50-1	1E0415	5.0	230	60	84	1-1/2"	1-1/2"	63
HE 1.5 50-1 CE	1E0512	5.0	230	60	84	1-1/2"	1-1/2"	63
HE 1.5 50	1E0511	5.0	220/440	60	84	1-1/2"	1-1/2"	48
HE 1.5 60	1E0513	6.0	220/440	70	86	1-1/2"	1-1/2"	60
HE 1.5 75	1E0514	7.5	220/440	80	94	1-1/2"	1-1/2"	61

* La altura (H) máxima se logra con la válvula totalmente cerrada. (mca= metros columna de agua).

** El caudal (Q) máximo se logra con la válvula totalmente abierta. (gpm= galones por minuto).



Materiales	
Cuerpo	Hierro fundido ASTM A-48, Clase 30
Impulsor	Hierro fundido ASTM A-48, Clase 30
Sello mecánico	Carbón/Cerámica/Buna-N
Acople intermedio	Hierro fundido ASTM A-48, Clase 30
Empaques	Buna Nitrilo

Características de la bomba	
Tipo de bomba	Centrífuga
Tipo de acoplamiento	Monobloque
Succión	1-1/2" NPT
Descarga	1-1/2" NPT
Tipo de impulsor	Cerrado <small>Balanceado dinámicamente según ISO G6,3</small>
Cantidad de impulsores	1
Tipo de sello	Sello mecánico 1-1/4" TIPO 21
Temperatura Max. Líquido	158° F (70 ° C) Continua

Características del Motor	
Tipo	Eléctrico
Potencia	5.0/6.0/7.5Hp(Segun modelo)
Diseño	NEMA JM
Velocidad	3.600 RPM (nominal)
Aislamiento	Clase F
Voltaje	220/440
Factor de servicio	1,15
Frecuencia	60Hz
Fases	1 ó 3 (Según modelo)

Aplicaciones	
•	Aprovisionamiento de aguas limpias
•	Recirculacion de agua en torres de enfriamiento
•	Refrigeracion de maquinaria/Circuitos de recirculacion
•	Sistemas de Presión
•	Equipos contra incendio
•	Plantas de tratamiento
•	Riego por goteo
•	Llenado de tanque bajo y tanque alto

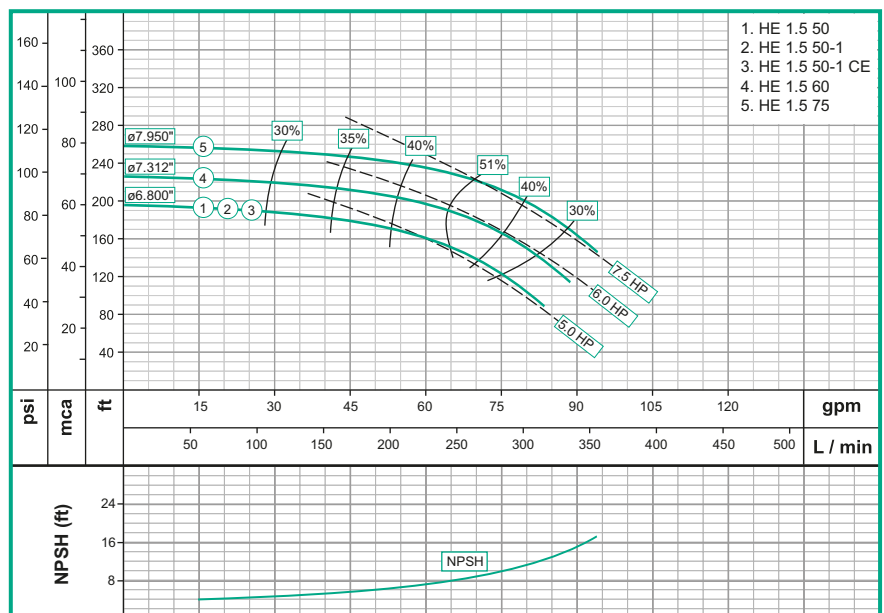

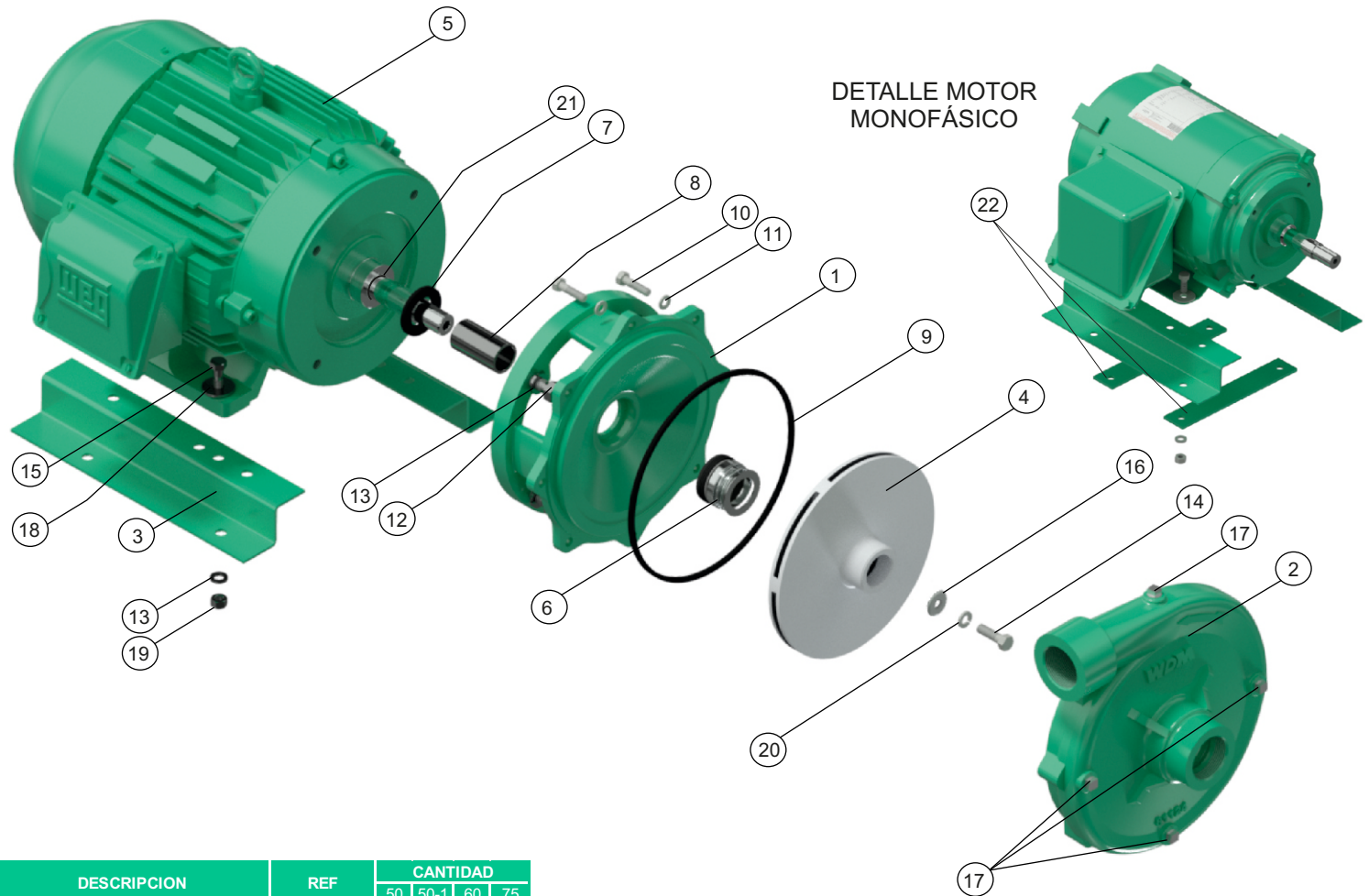

N°	DESCRIPCION	REF	CANTIDAD			
			50	50-1	60	75
1	ACOPLE EN HIERRO	22023	1	1	1	1
2	CUERPO EN HIERRO	31426	1	1	1	1
3	BASE EN LAMINA	30176	2	2	2	2
4	IMPULSOR ø6,800"	37680	1			
4	IMPULSOR ø6,900"	37690		1		
4	IMPULSOR ø7,312"	37731			1	
4	IMPULSOR ø7,950"	37795				1
5	MOTOR 5.0HP MONOFASICO	25299		1		
5	MOTOR 5,0HP TRIFASICO	25000013979	1			
5	MOTOR 6,0 TRIFASICO	25000015002			1	
5	MOTOR 7,5HP TRIFASICO	25000013958				1
6	SELLO MECANICO 1-1/4"	00050	1	1	1	1
7	ARANDELA DE CAUCHO	05163	1	1	1	1
8	CAMISA INOXIDABLE	23864	1	1	1	1
9	ANILLO CUADRADO	21297	1	1	1	1
10	TORNILLO 5/16" x 1-1/4" NC	02220	8	8	8	8
11	ARANDELA DE PRESION 5/16"	02602	8	8	8	8
12	TORNILLO 3/8" x 1"NC	02037	4	4	4	4
13	ARANDELA DE PRESION 3/8"	02604	8	8	8	8
14	TORNILLO 3/8" x 1-1/4"INOX	02215	1	1	1	1
15	TORNILLO 3/8" x 1-1/4"NC	02236	4	4	4	4
16	ARANDELA RETENCION	26814	1	1	1	1
17	TAPON DE 1/4" NPT	03201	4	4	4	4
18	ARANDELA PLANA DE 3/8"	02553	4	4	4	4
19	TUERCA DE 3/8"	02502	4	4	4	4
20	ARANDELA DE PRESION 3/8"INOX	02616	1	1	1	1
21	ANILLO "O" 2-020	17433	1	1	1	1
22	PLATINA PARA BASE	19350	2			

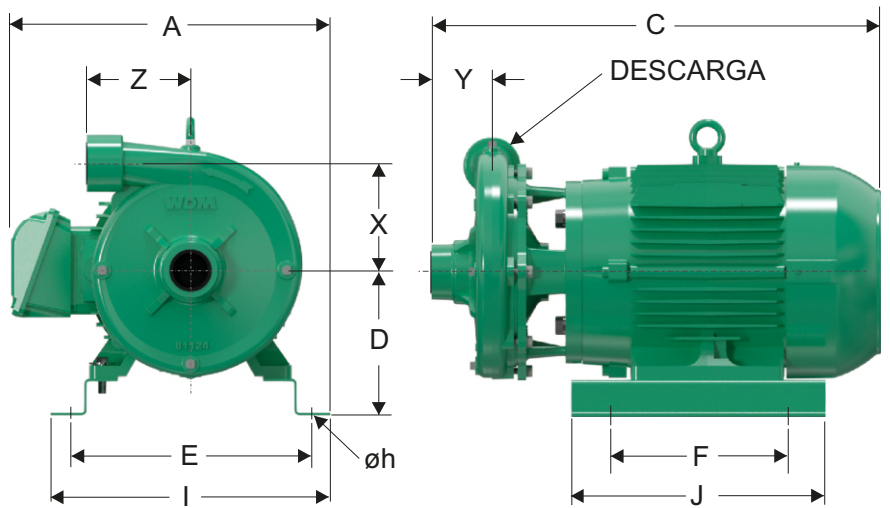

DIMENSIONES EN MILIMETROS

MODELO	SUCxDESC	C	A	E	D	F	J	X	Y	Z	I	øh
HE1,5 50-1	1-1/2" x 1-1/2"	521	373	280	159	178	312	127	74	130	317	11
HE1,5 50	1-1/2" x 1-1/2"	498	311	249	145	178	312	127	74	130	287	11
HE1,5 60	1-1/2" x 1-1/2"	530	335	249	145	178	312	127	74	130	287	11
HE1,5 75	1-1/2" x 1-1/2"	530	335	249	145	178	312	127	74	130	287	11