

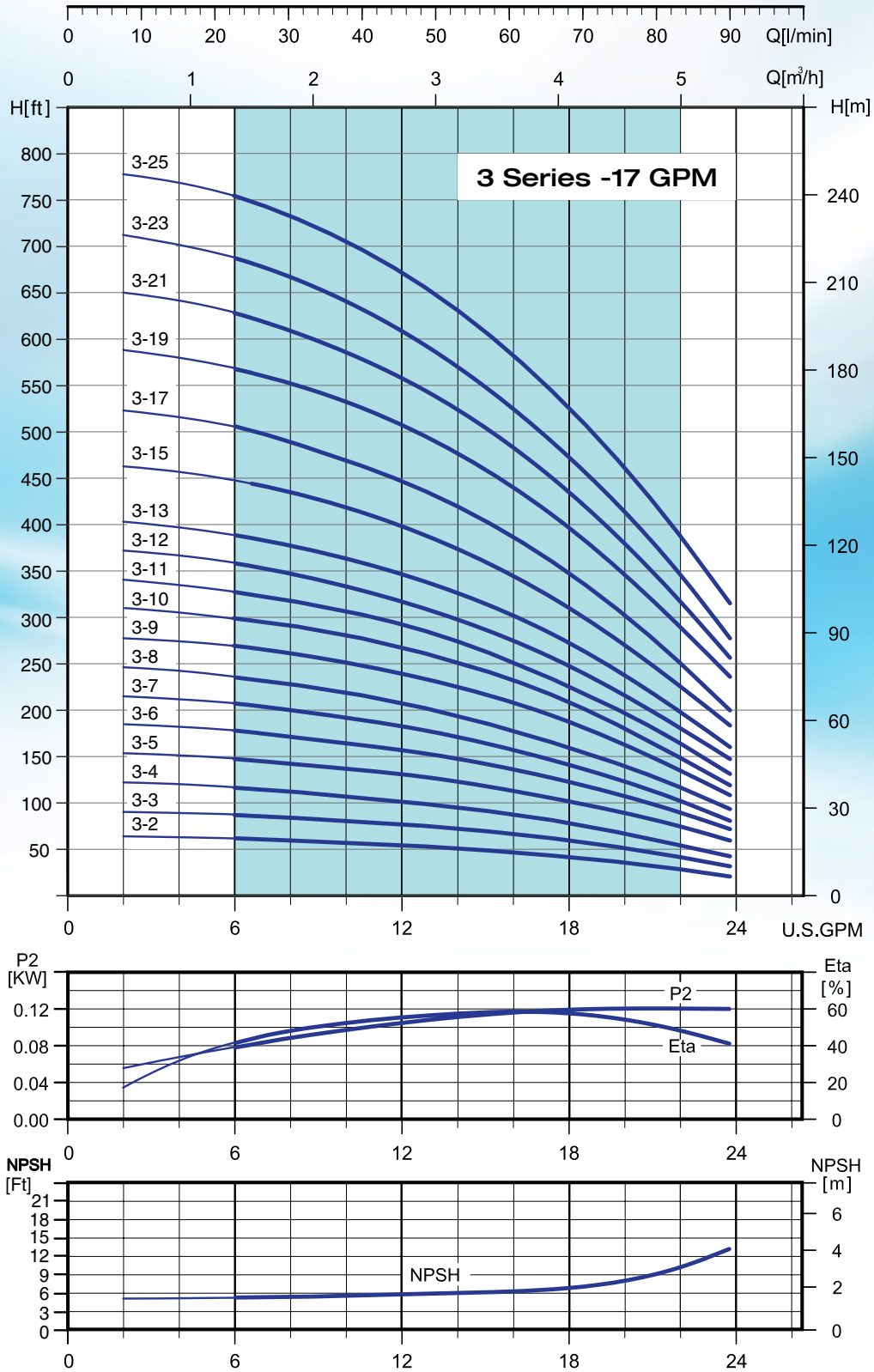

VPS 3 MOTOR IEC

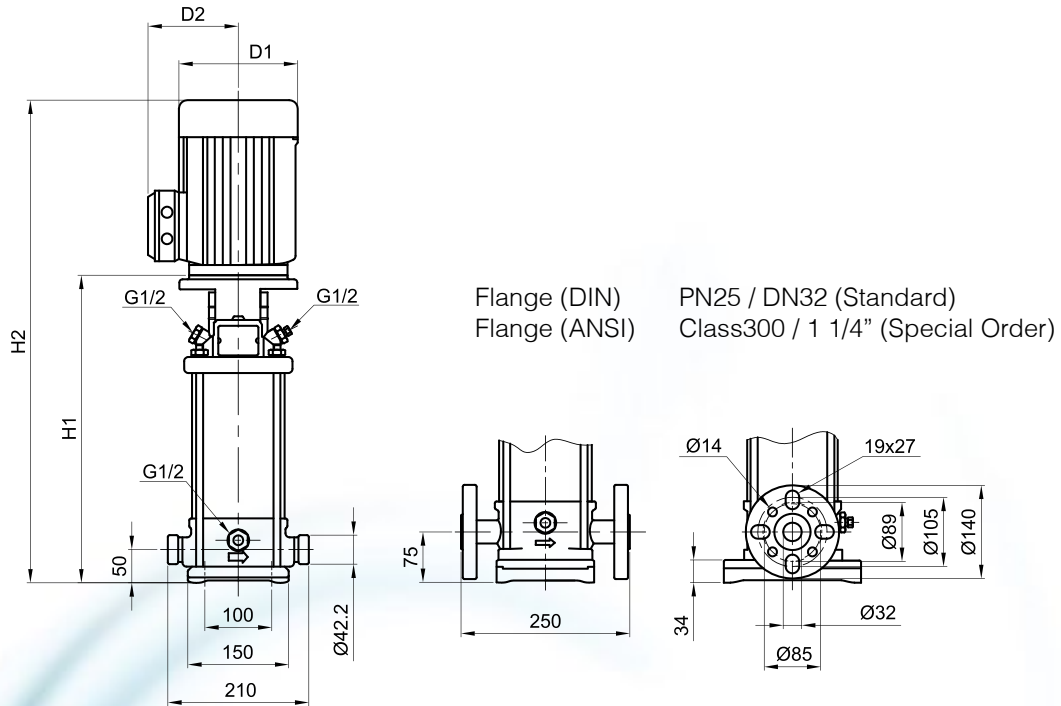

Peso y Dimensiones



MODELO	HP	ACOPLE	DIMENSIONES Y PESO SERIE VPS - MOTORES IEC									
			H1		H2		D1		D2		PESO NETO	
			in	mm	in	mm	in	mm	in	mm	lbs	kg
TRIFASICO												
VPS 3-2	0.5	71	11 1/8	282	19	477	5 5/8	141	4 5/8	115	45	21
VPS 3-3	0.75	80 M	11 1/8	282	19	477	5 5/8	141	4 5/8	115	46	21
VPS 3-4	0.75	80 M	12	300	19 1/2	495	5 5/8	141	4 5/8	115	47	22
VPS 3-5	1	80A	13	324	22 1/8	559	5 5/8	141	4 5/8	115	52	24
VPS 3-6	1.5	80B	13 1/2	342	25	631	7	177	5 5/8	141	68	31
VPS 3-7	1.5	80B	14 1/4	360	25 5/8	649	7	177	5 5/8	141	69	31
VPS 3-8	1.5	80B	15	378	26 3/8	667	7	177	5 5/8	141	70	32
VPS 3-9	2	90S	16 1/4	412	28	707	7	177	5 5/8	141	80	36
VPS 3-10	2	90S	17	430	28 5/8	725	7	177	5 5/8	141	80	37
VPS 3-11	2	90S	17 3/4	448	29 3/8	743	7	177	5 5/8	141	81	37
VPS 3-12	3	90L	18 3/8	466	30	761	7	177	5 5/8	141	86	39
VPS 3-13	3	90L	19 1/8	484	30 3/4	779	7	177	5 5/8	141	87	40
VPS 3-15	3	90L	20 1/2	520	32 1/8	815	7	177	5 5/8	141	88	40
VPS 3-17	3	90L	22	556	33 1/2	851	7	177	5 5/8	141	90	41
VPS 3-19	4	100L	23 5/8	597	36	913	8	197	6	147	111	50
VPS 3-21	4	100L	25	633	37 3/8	949	8	197	6	147	112	51
VPS 3-23	4	100L	26 3/8	669	39	985	8	197	6	147	114	52
VPS 3-25	5.5	112M	28	705	40 5/8	1031	8 3/4	220	6 3/8	161	124	57

Todas las medidas son de referencia. Los valores podrán cambiar según el modelo del motor.



VPS 3 MOTOR NEMA

