

GXR, GXV 60 Hz Submersible Pumps in stainless steel



Construction

Single-impeller submersible pumps in chrome-nickel stainless steel, with vertical delivery port.

GXR: with open impeller.

GXV: with free-flow (vortex) impeller.

Motor cooled by the pumped water passing between the motor jacket and the external jacket.

Double shaft seal with oil chamber.

Minimum dimension and high levels of performance, for use in many different applications, head up to 12,7 m and flow rates up to 220 liters/min.

Applications

GXR: - For clean water containing solids up to 10 mm grain size.
 - For draining rooms or emptying tanks.
 - Extraction of water from ponds, streams or pits and for rainwater collection.
 - For irrigation purposes.

GXV: - For clean or slightly dirty water, containing solids up to 25 mm grain size.

- Particularly suitable for liquids with a high solid content.

For outdoor use a power supply cable of not less than 10 m should be used in accordance with: EN 60335-2-41.

Operating conditions

Liquid temperature up to 50° C.

Maximum immersion depth: 5 m.

Minimum water level with float: GXR = 70 mm, GXV = 130 mm.

Minimum water level manual operation: GXR = 15 mm, GXV = 30 mm.

Continuous duty.

Motor

2-pole induction motor, 60 Hz ($n = 3450$ rpm).

GXR, GXV: three-phase 220 V;

three-phase 380 V;

GXRM, GXVM: single-phase 220 V,

with float switch and thermal protector.

Incorporated capacitor.

Insulation class F.

Protection IP X8 (for continuous immersion)

Double impregnation humidity-proof dry winding.

Constructed in accordance with: EN 60335-2-41.

Materials

Component	Material
Pump casing	Chrome-nickel steel AISI 304
Strainer	Chrome-nickel steel AISI 304
Impeller	Chrome-nickel steel AISI 304
Motor jacket	Chrome-nickel steel AISI 304
Pump jacket	Chrome-nickel steel AISI 304
Handle	Polypropylene
Shaft	Chrome-nickel steel AISI 303
Mechanical seal	Ceramic alumina/Carbon/NBR
Seal lubrication oil	Oil for food/pharmaceutical machinery

Other features on request

- Other voltages. - Other mechanical seal.
- Cable length 10 m. - Vertical magnetic float switch.

Characteristic curves $n = 3450$ rpm

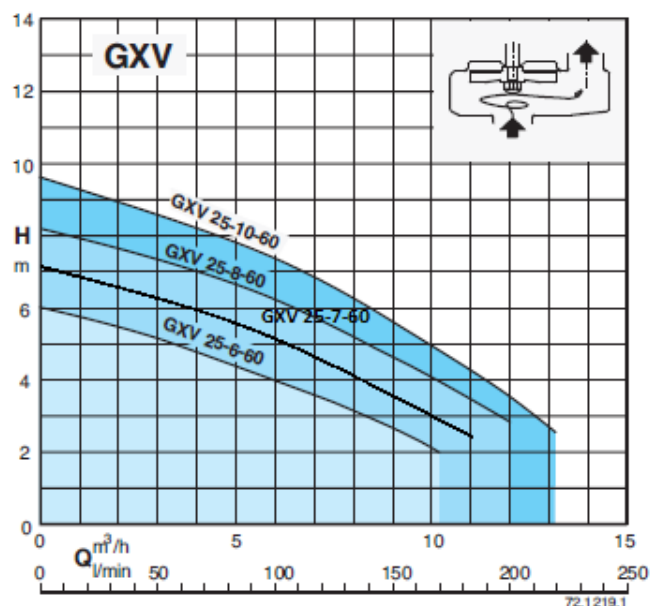
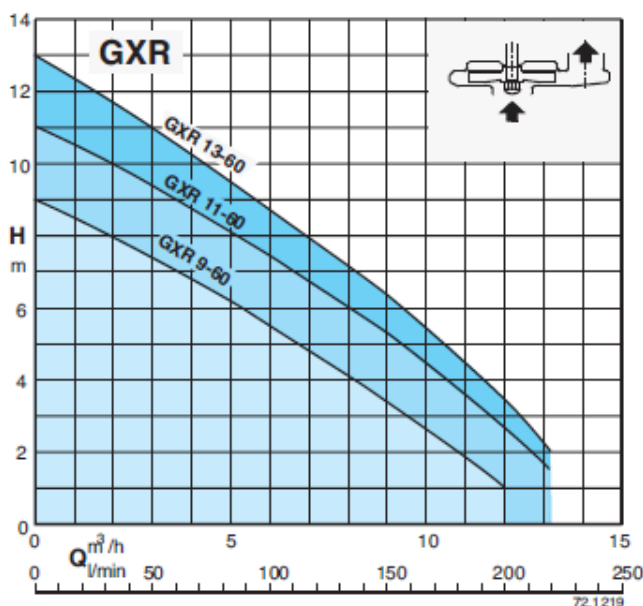

GXR, GXV 60 Hz Submersible Pumps in stainless steel



Performance n = 3450 rpm

3~	220V 380V			1~	220V		P ₂		Q m ³ /h l/min	0	1,2	3	4,5	6	7,5	9	10,2	12	13,2
	A	A	IA/IN		A	IA/IN	kW	HP											
GXR 9-60	1,4	0,8	3,8	GXR_M 9-60	2,5	2,3	0,25	0,33	H m	9	8,5	7,5	6,5	5,5	4,5	3,4	2,3	1	
GXR 11-60	3,1	1,8	3,8	GXR_M 11-60	3,6	2,3	0,37	0,5		11	10,4	9,5	8,5	7,3	6,3	5,3	4,4	2,7	1,7
GXR 13-60	3,4	2	3,5	GXR_M 13-60	4,9	2,5	0,45	0,6		13	12,2	11	10	8,7	7,8	6,3	5,3	3,5	2

3~	220V 380V			1~	220V		P ₂		Q m ³ /h l/min	0	1,2	3	4,5	6	7,5	9	10,2	12	13,2
	A	A	IA/IN		A	IA/IN	kW	HP											
GXV 25-6-60	1,4	0,8	3,8	GXV_M 25-6-60	2,5	2,3	0,25	0,33	H m	6	5,7	5,2	4,6	4	3,3	2,6	2		
GXV 25-7-60	1,4	0,8	3,8	GXV_M 25-7-60	2,5	2,3	0,25	0,33		7	6,7	6,2	5,7	5	4,2	3,2	2,4		
GXV 25-8-60	3,1	1,8	3,8	GXV_M 25-8-60	3,6	2,3	0,37	0,5		8,2	7,8	7,3	6,8	6,2	5,5	4,7	4	3	
GXV 25-10-60	3,4	2	3,5	GXV_M 25-10-60	4,9	2,5	0,45	0,6		9,5	9,2	8,7	8,2	7,5	6,6	5,6	4,8	3,5	2,6

P₂ Rated motor power output. Density $\rho = 1000 \text{ kg/m}^3$. Kinematic viscosity $\nu = \text{max } 20 \text{ mm}^2/\text{sec}$. Tolerances according to ISO 9906, annex A.
IA/IN = D.O.L. starting current / Rated current.

Pump type	Power supply cable				Float switch	
	Cable material	Section	Length	Plug CEE 7(VII)	Cable material	Section
GXR _M 9-60 GXV _M 25-6-60, 25-7-60	H05RN-F	3G0,75 mm ²	5 m	YES	H07RN-F	3G1 mm ²
GXR _M 11-60, 13-60 GXV _M 25-8-60, 25-10-60	H07RN-F	3G1 mm ²	5 m	YES	H07RN-F	3G1 mm ²
GXR 9-60 GXV 25-6-60, 25-7-60	H05RN-F	4G0,75 mm ²	5 m	NO	NO	-
GXR 11-60, 13-60 GXV 25-8-60, 25-10-60	H07RN-F	4G1 mm ²	5 m	NO	NO	-

Dimensions and weights

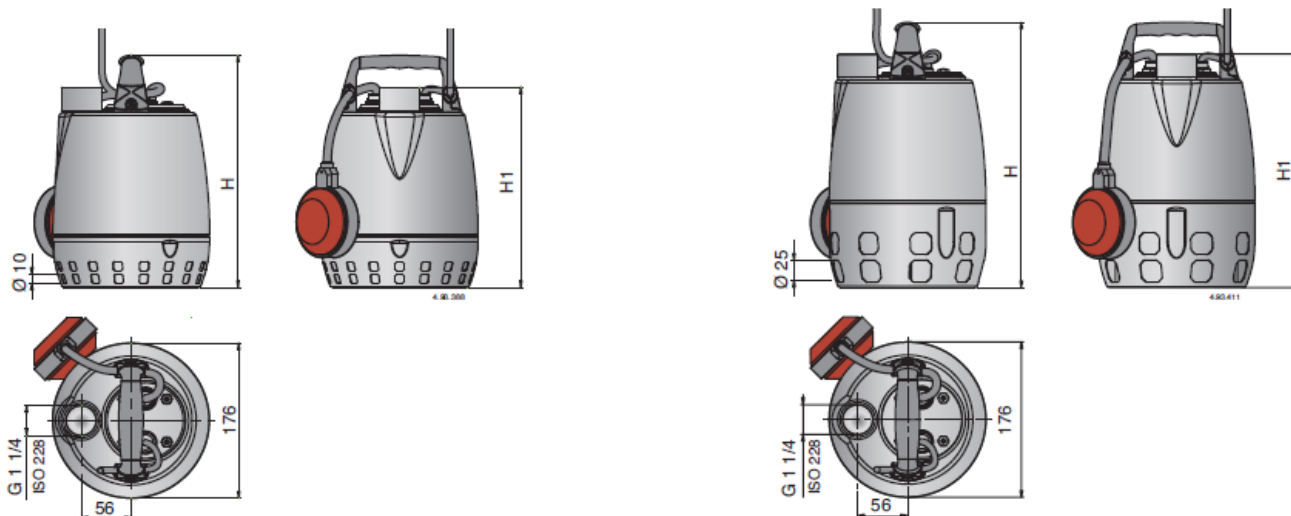

TYPE	Dimensions mm		(1) kg	
	H	H1	GXR	GXR _M
GXR 9-60 - GXR_M 9-60	265	230	5	5,2
GXR 11-60 - GXR_M 11-60	300	265	6,2	6,5
GXR 13-60 - GXR_M 13-60	300	265	6,7	7,2

(1) With cable length: 5 m

TYPE	Dimensions mm		(1) kg	
	H	H1	GXV	GXV _M
GXV 25-6-60 - GXV_M 25-6-60	302	267	5,1	5,3
GXV 25-7-60 - GXV_M 25-7-60	302	267	5,1	5,3
GXV 25-8-60 - GXV_M 25-8-60	337	302	6,3	6,6
GXV 25-10-60 - GXV_M 25-10-60	337	302	6,8	7,3

(1) With cable length: 5 m

GXR, GXV 60 Hz

Submersible Pumps
in stainless steel



Installation examples

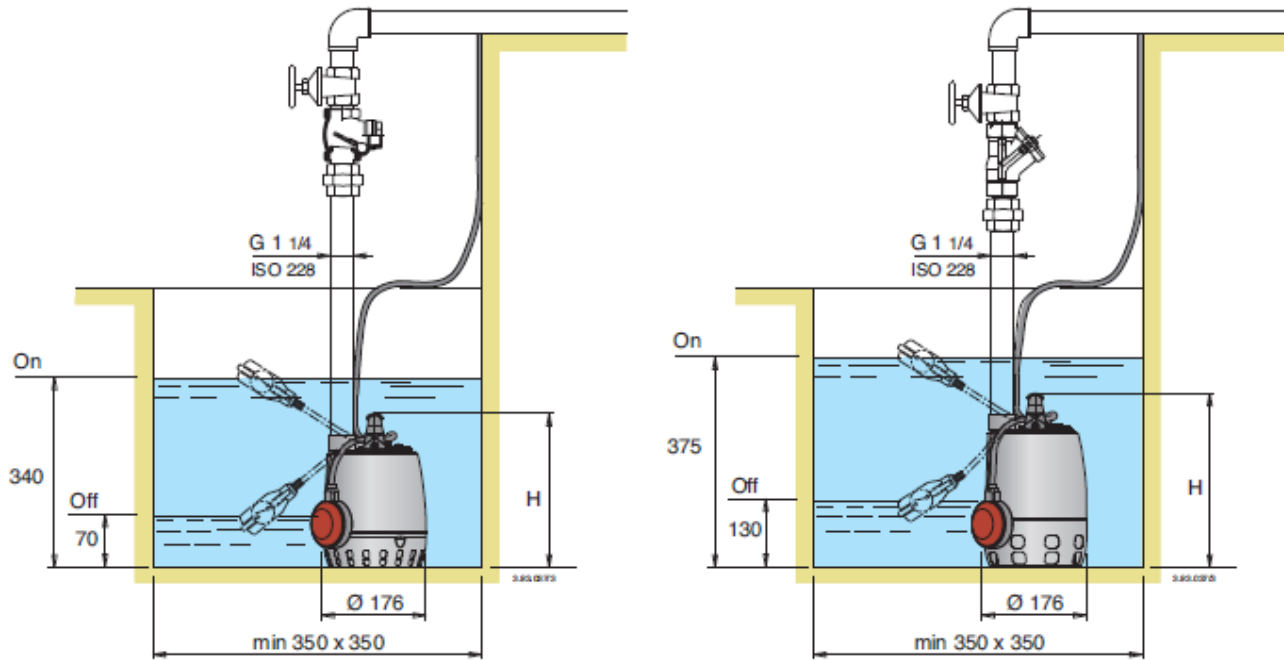

Installation examples with vertical magnetic float switch

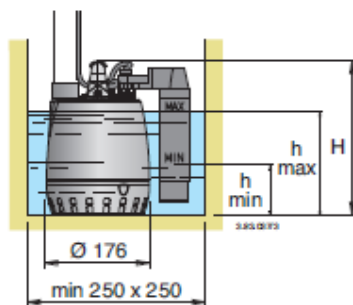

TYPE	mm		
	H	h min	h max
GXRM 9-60 GF	265	100	190
GXRM 11-60 GF	300	135	225
GXRM 13-60 GF	300	135	225

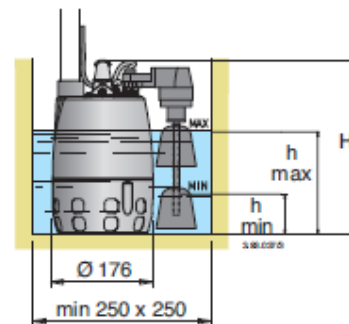

TYPE	mm		
	H	h min	h max
GXVM 25-6-60 GF	302	60	150
GXVM 25-8-60 GF	337	60	185
GXVM 25-10-60 GF	337	60	185

GXR, GXV

60 Hz

Submersible Pumps
in stainless steel



Features

PATENTED

G 1 1/4 vertical, upward delivery port for installation in small pits, without the need for an elbow on the pump.

Handle in polypropylene.

Easy inspection of the capacitor area

Shaft in chrome-nickel stainless steel.

Motor cooled by the pumped water passing between the motor jacket and the external jacket.

Ceramic stainless steel shaft sleeve

Oil chamber

Suction strainer with a double row of holes, for extra safety against clogging. GXR: it allows the passage of solids up to 10 mm.

Impeller in chrome-nickel stainless steel.

Easy adjustment of the float switch: to allow the adjustment of start/stop pump levels

Suction strainer with a double row of holes, for extra safety against clogging. GXV: it allows the passage of solids up to 25 mm.

The double shaft seal with oil chamber separates the motor from the water and provides further protection against accidental operation when dry.

