

Technical Data

Pump Name

DW VOX 2006

Cliente	Fecha 27/08/2024	Empresa
Contacto	Ref.	Issued by
Teléfono	Proyecto	Teléfono
Correo electrónico	ID proyecto	Correo electrónico

Datos solicitados

1	Tipo	SUBMERSIBLE SEWAGE PUMPS	Fluido	Agua
2	Número de bombas / Reserva	1 / 0	Temperatura del fluido °C	20
3	Caudal l/min		Viscosidad cinemática cSt	1.005
4	Altura de impulsión m		Presión de vapor psi	0.3394
5	Altura geodésica m		Valor PH	
6	Presión de entrada (pin) psi	0	Densidad kg/m ³	998.3
7	NPSH - valor de la instalación		Sólidos Weight %	0
8	Temperatura ambiente °C	20		

Bomba

9	Pump Name	DW VOX 2006	Frecuencia Hz	60
10	Diseño	SUBMERSIBLE SEWAGE PUMPS	Instalación	STANDARD
11	Fabricante	EPE	Rodete Diámetro	Máx. mm 90
12	Velocidad 1/min	3400		Diseñado mm 90
13	No. of Stage	1		Min. mm 90
14	Conexión Lado aspiración	UNI ISO 228	Caudal	Operating l/min
15	Conexión Lado impulsión	UNI ISO 228		Max- l/min 700
16	Max Working Pressure psi			Min- l/min 100
17	cabeza de cierre psi	20.56	Altura de impulsión	Operating m
18	Peso total kg	See the table of "Dimensions".		- (Qmax.) m 2.6
19	Potencia absorbida hp			- (Qmin.) m 13.3
20			Potencia del eje a máx. hp	
21	NPSH requerido (bomba) m		Eficiencia %	

Materiales

22	Impeller	AISI 304		
23	Casing	AISI 304		
24	Shaft	AISI 303 (wet extension)		
25				
26				
27				

Motor

28	Fabricante	EPE Standard	Clase de aislamiento	F
29	Tipo	DW VOX M 2006_220_Single Phase	Fases	1~
30	Ejecución	Submersible dry type / 60 Hz / Pares de polos 1	Tamaño de construcción	
31	Potencia hp	2.0115	Peso kg	
32	Nº de polos	2	Tensión eléctrica V	220
33	Velocidad 1/min	3400	Corriente eléctrica A	11.1
34	Grado de protección	IP X8		
35				

Remarks

Performance Curve

Pump Name

DW VOX 2006

Ciente	Fecha 27/08/2024	Empresa
Contacto	Ref.	Issued by
Teléfono	Proyecto	Teléfono
Correo electrónico	ID proyecto	Correo electrónico

Datos solicitados

1	Caudal	l/min	
2	Altura de impulsión	m	
3	Altura geodésica	m	

Bomba

Operating flow	l/min	Frecuencia	Hz	60
Operating head	m	Nº de polos		2
Diámetro del impulsor diseñado	mm	90	Velocidad	1/min 3400

Test standard: ISO 9906:2012 - Grade3B

Agua; 20°C; 998.3kg/m³; 1cSt

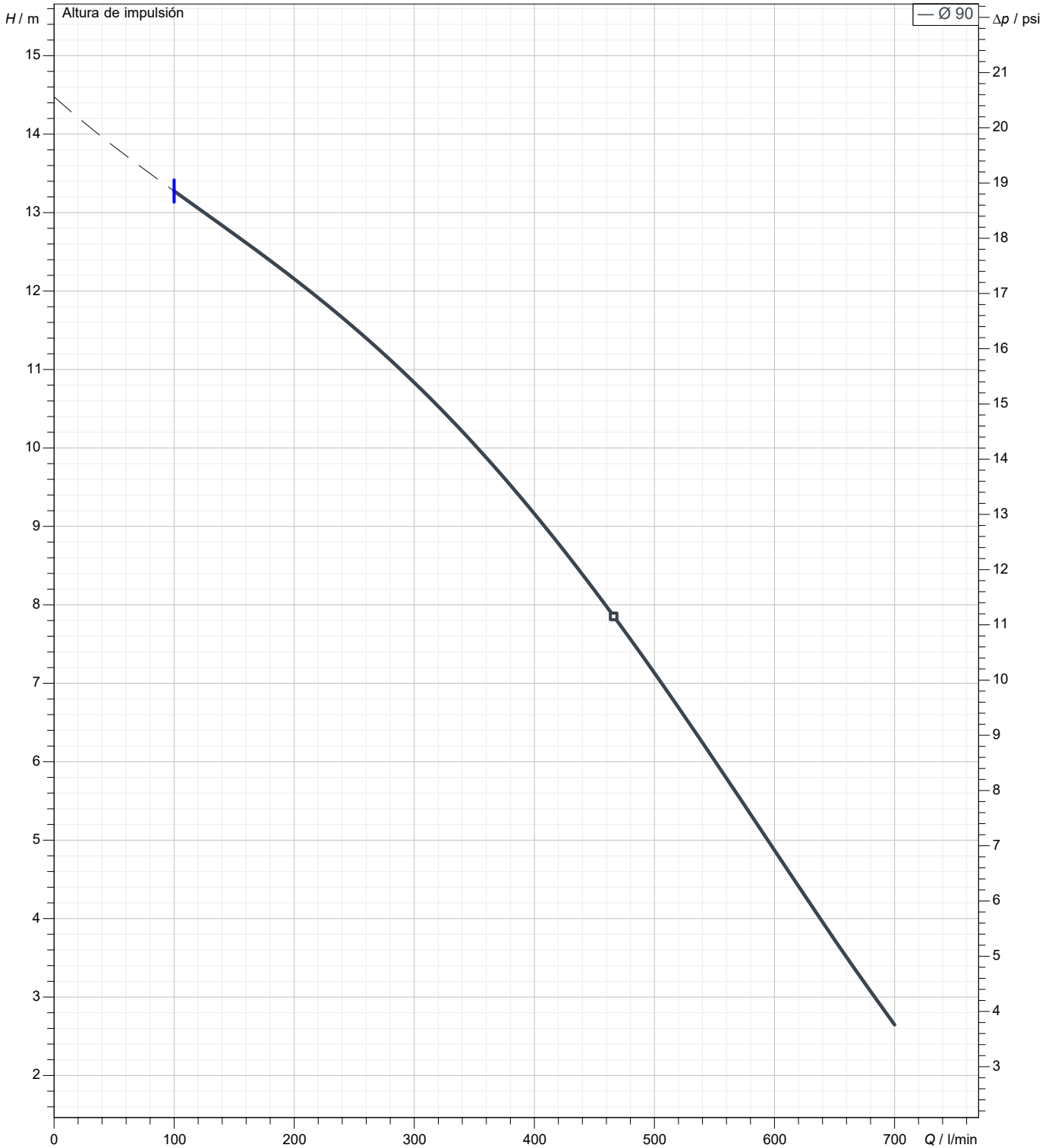

Dimensiones

Nombre de la bomba DW VOX 2006

Cliente	Fecha 27/08/2024	Empresa
Contacto	Ref.	Issued by
Teléfono	Proyecto	Teléfono
Correo electrónico	ID proyecto	Correo electrónico

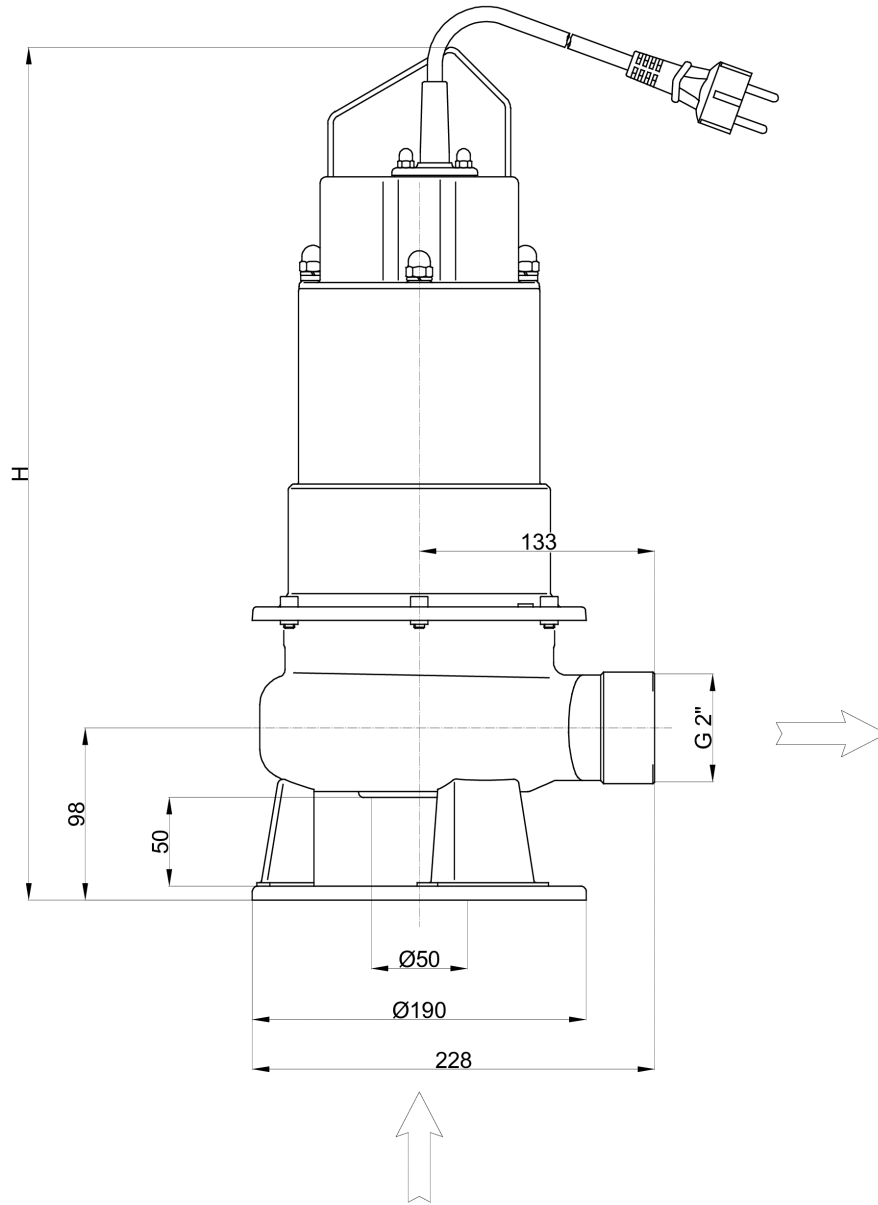

Dimensiones		mm						
1	H	516						
2	Weight PUMP	19,6 kg						
3								
4								
5								
6								
7								
8								
9								
10								
11								
12								
13								
14								
15								

Cliente	Fecha 27/08/2024	Empresa
Contacto	Ref.	Issued by
Teléfono	Proyecto	Teléfono
Correo electrónico	ID proyecto	Correo electrónico

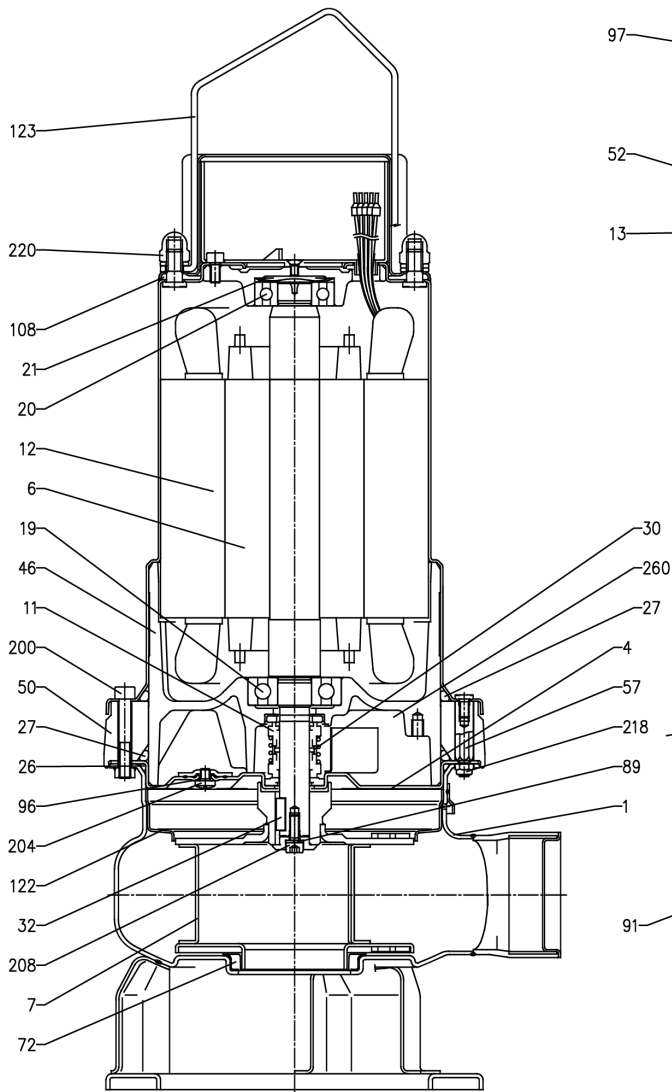

DW

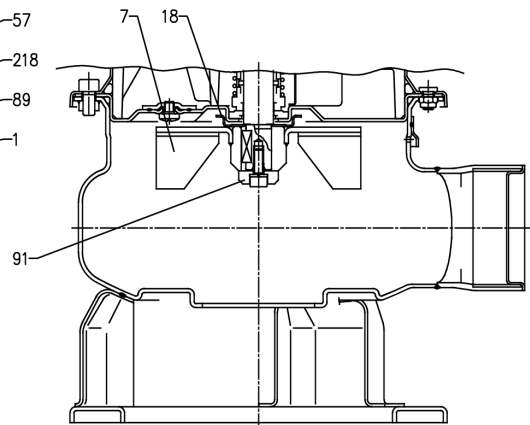
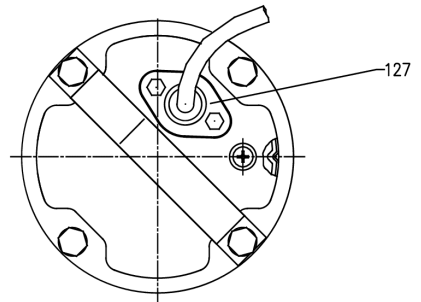
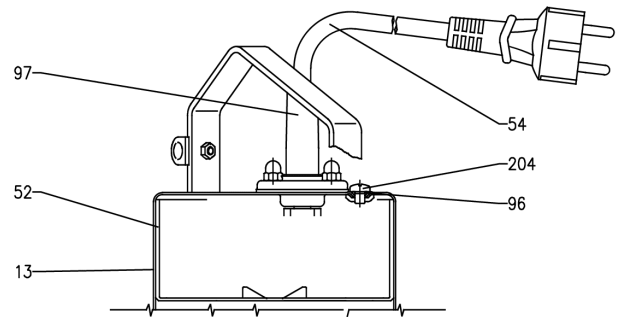

DW VOX

(2/3)

Construcción

Nombre de la bomba DW VOX 2006

Cliente	Fecha 27/08/2024	Empresa
Contacto	Ref.	Issued by
Teléfono	Proyecto	Teléfono
Correo electrónico	ID proyecto	Correo electrónico

Nº	PART NAME	MATERIAL	Q.TY
1	Casing	AISI 304	1
4	Casing cover	AISI 304	1
6	Shaft with rotor	AISI 303	1
7	Impeller	AISI 304	1
11	Mechanical seal impeller side [5]	SiC/SiC/NBR	1
11	Mechanical seal motor side [5]	Carbon/Ceramic/NBR	1
12	Motor frame with stator	-	1
13	Motor cover	AISI 304	1
16	Terminal	-	1
18	Mechanical seal protection [1]	AISI 304	1
19	Lower side ball bearing	-	1
20	Upper side ball bearing	-	1
21	Adjusting ring	Steel C70	1
26	O ring	NBR	1
27	O ring [2]	NBR	1
30	Mechanical seal spacer	Brass	1
32	Key	AISI 316	1
46	Bearing housing	G20	1
50	Spacer [2]	G20	1
52	Terminal insulating box	PA66 glass fibre reinforced class V-0	1
54	Power cable	-	1
57	Spacer [2]	AISI 304	4
72	Casing ring [3]	NBR	1
89	Washer	AISI 304	1
91	Washer [1]	AISI 304	1
96	O ring	NBR	3
97	Power cable entry	NBR	1
108	Cover gasket	NBR	1
122	Impeller protection ring [4]	AISI 304	1
123	Handle	AISI 304	1
127	Power cable connector	AISI 304	1
200	Screw	Stainless steel A2 UNI 7323	6
204	Screw	Stainless steel A2 UNI 7323	3
208	Screw	Stainless steel A2 UNI 7323	1
218	Nut	Stainless steel A2 UNI 7323	4
220	Nut	Stainless steel A2 UNI 7323	4
260	Lubricating liquid	White mineral oil	385 cc

- [1] Except for DW-DW VOX 3006
- [2] Only for DW-DW VOX 3006
- [3] Only for DW
- [4] Except for DW VOX 1506, 2006 and 3006
- [5] See **CONSTRUCTION 3**

(3/3)

Construcción

Nombre de la bomba DW VOX 2006

Cliente	Fecha 27/08/2024	Empresa
Contacto	Ref.	Issued by
Teléfono	Proyecto	Teléfono
Correo electrónico	ID proyecto	Correo electrónico

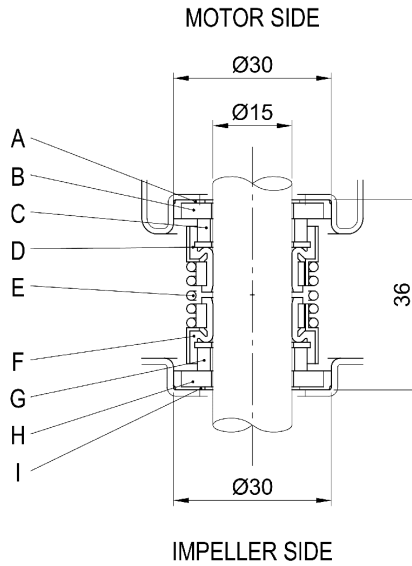

REF	PART NAME	MATERIAL
A	Rubber cup	NBR
B	Seat	Ceramic
C	Seal face	Carbon
D	Bellow	NBR
E	Spring	AISI 304
F	Bellow	NBR
G	Seal face	Silicon carbide
H	Seat	Silicon carbide
I	Rubber cup	NBR